

CM2

The CM2 is a composting toilet that uses the natural process of aerobic decomposition to transform human faecal waste, urine and toilet paper into humus that is safe to dispose of in a manner compliant with local health authority or as described in this manual.



Thank you for your purchase of a CM2 compost toilet. With proper installation and maintenance we are certain it will offer you a convenience and reliability you would expect from the manufacture of the best selling septic free toilet in the world. Please, read these instructions carefully, as they will give you vital information about installing and maintaining your CM2.

Capacity: 2 person full time use

Specifications

	4 person part time use.
Max Weight:	130kg
Material:	LDPE
Dimension:	620 L x 395 W x 500 H
Operating Temperature:	Subjected to temperature & number of compost chambers
Ventilation Fan:	2W 12V DC

Electrical Requirements

Go Green | Pay Less | No Mess

Clivus Multrum Australia

Phone: 1300 138 182
Phone: 07 3889 6144
Email: info@clivusmultrum.com.au

CONTENTS

1.0	PACKAGE CONTENTS	3
2.0	INSTALLATION	4
2.1	Tools Required	4
2.2	Materials Required	4
2.3	Pedestal Installation	4
2.4	Ventilation Pipe	5
2.5	Ventilation Fan	7
2.6	Passive Ventilation Option	7
2.7	Signage	7
2.8	Excess liquid Drain Installation	8
2.8.1	Option I—Absorption Trench	8
2.8.2	Option II—25 Litre Translucent Container	8
3.0	USING THE CM2	9
3.1	Initial Setup	9
4.0	MAINTENANCE	9
4.1	General Care	9
4.2	Removing The Chamber	9
4.3	When Do I Empty The Secondary Chamber?	9
4.4	How Do I Dispose The Composted End Product?	10
4.5	Adding Wood Shavings	10
4.6	Insect	10
4.7	Cleaning	10
4.8	Warning	10
5.0	HOW COMPOSTING WORKS	11
5.1	General	11
5.2	Moisture	11
5.3	Temperature	11
5.4	Aeration	11
5.5	Pathogens	11
6.0	WARRANTY	12
7.0	TROUBLESHOOTING	12

1.0 PACKAGE CONTENTS

Please ensure that the package you received contains all items listed in the **packing list** document no: PSCM-002 that comes with your CM2 package.

If anything is missing, please contact your supplier immediately.

PEDESTAL	1
TOILET SEAT PLASTIC	1
COMPOST CHAMBER	2
COMPOST CHAMBER LID	2
MOUNTING BLOCKS & SCREWS w/ WASHERS x4	2
OPERATING MANUAL	1
ACRYLIC HOW TO USE SIGN w/ SCREWS x4	1
PLUMBING:	
100mm 45 DEG BEND	1
100mm COVERED VENT COWL	1
25mm DRAINAGE HOSE (LENGTH 1.2m)	1
25mm HOSE CONNECTOR	1
50mm FLOOR FLANGE	1
50mm WALLACE SEAL (greased & sealed)	1
50mm MOISTURE TRAP "T" JUNCTION w/ CAP	1
50mm PVC DWV PIPE (LENGTH 600mm)	1
HOSE CLAMP	1
ELECTRONICS:	
240-12V TRANSFORMER (w/ CRIMP WIRE CONNECTORS x2)	1
100mm to 50mm PVC REDUCER w/ 80mm 12V 2W FAN	1
STARTER PACKAGE:	
125ML NATURE FLUSH ENZYMES	1
500ML SPRAY FLASK	1
WOODSHAVINGS ONLY 1 x 15L BAG	1
TOILET PAPER ROLL & PAMPHLET	1
SOLAR PACKAGE:	
20W PANEL w/ 7Ah BATTERY OR	1
40W PANEL w/ 35Ah BATTERY	1
APPLE CONTROLLER w/ CABLES (Soldered. In Panel Box)	1

2.0 INSTALLATION

This section outlines the requirements and procedures to ensure trouble free installation. Please follow the instructions exactly and contact Clivus Multrum for any installation questions.

2.1 Tools Required

- I. Drill
- II. Hole Saw 38mm & 65mm (Min. sizes)
- III. Hand Saw
- IV. Screwdriver
- V. Tape Measure
- VI. 100% Silicon Adhesive Sealant with Caulking Gun
- VII. Pencil
- VIII. Spirit Level
- IX. Spade

2.2 Materials Required

- I. Additional 4" DWV PVC pipe and fittings for ventilation pipe depending on installation requirements.
- II. 4" vent pipe supports and wall or roof flashing depending on installation requirements.
- III. PVC pipe glue.
- IV. Drain kit or excess fluid container if not purchased from Clivus Multrum.

2.3 Pedestal Installation

The CM2 can be installed close to a wall with the vent pipe exiting directly through the rear wall (Figure 1) or alternatively the vent pipe can be installed on the inside exiting up through the ceiling (Figure 2).

Figure 1: Ventilation pipe installed Outside.

Figure 2: Ventilation pipe installed Inside. (SPECIAL ORDER)

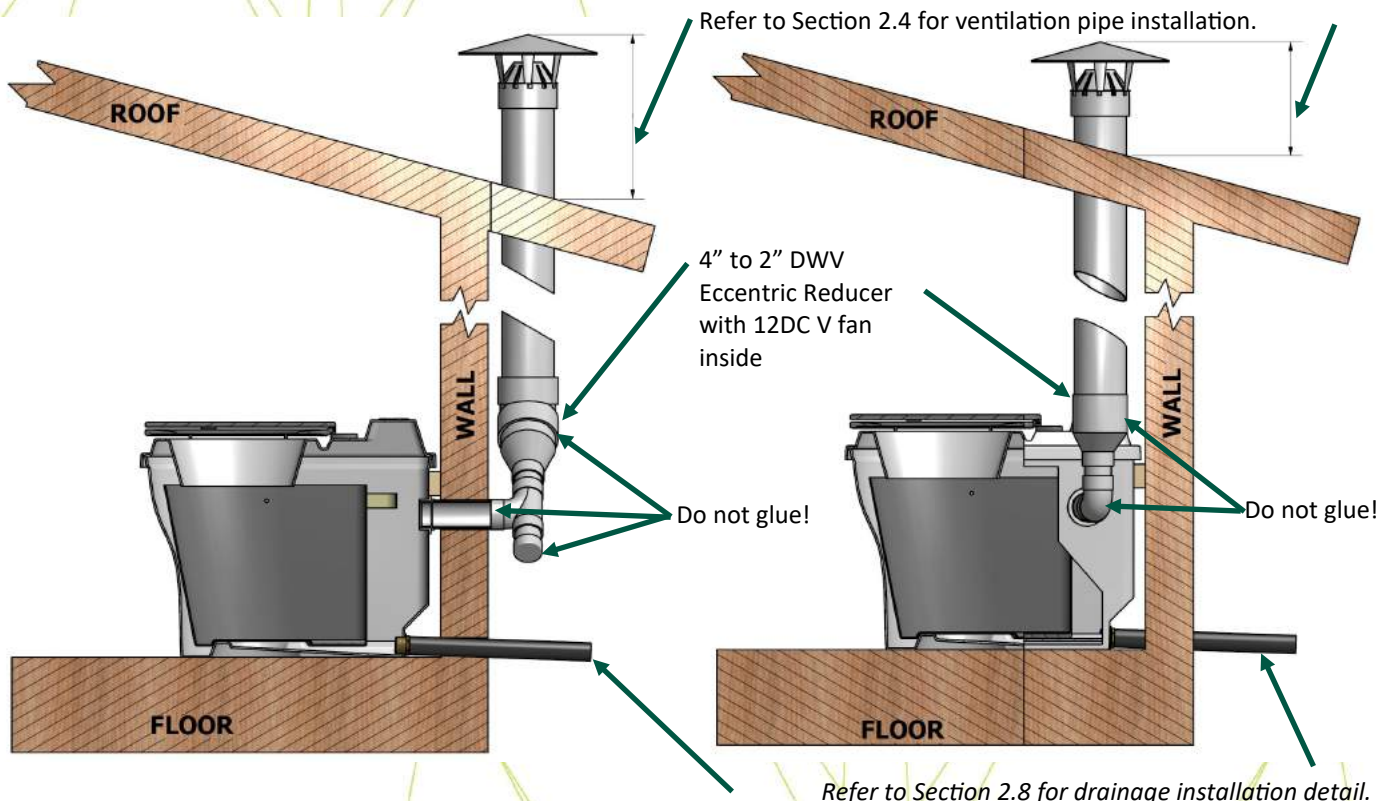

Continue next page...

2.0 INSTALLATION

The following instructions relate to Figure 1 and are the recommended installation procedures. This may vary depending on the location.

1. Unpack the unit and remove all contents from the pedestal.
2. Cut a 2" DWV PVC pipe to suit the thickness of your wall leaving sufficient length to connect the 2" Tee on the outside.
3. Insert the 2" DWV PVC pipe into the pedestal ventilation outlet. The Wallace seal for the vent outlet is pre-greased for ease of insertion of the 50mm vent pipe.
4. Position the pedestal with the rear against the wall.
5. Mark the ventilation and drain outlet positions on the wall.
6. Put the pedestal aside and drill through the wall for the drain pipe and ventilation pipe respectively.

NOTE: The drain pipe exit hole must be lower than the pedestal outlet.

7. Connect the drain hose to the pedestal using the hose barb and hose clamp.
8. Return the pedestal to the wall. Place the 50mm floor flange supplied in the hole drilled in the wall for the vent pipe. This gives it a tidy appearance. Feed the drain and vent pipe out through the wall. Using the mounting blocks provided, fix the pedestal to the wall by screwing through the rear wall of the pedestal and through the mounting blocks into the wall. At least 2 fixing points should be installed at a minimum of 100mm apart.
9. Proceed to exterior piping installation. Connect the 2" Tee, 2" Cap and 4" to 2" Eccentric Reducer (including 12V DC fan) as shown in Figure 1 or Figure 2. Additional pipe may be required. Refer to Section 2.4.

NOTE: Do not glue the Eccentric Reducer to the 4" 45° Elbow or 2" Tee to the 2" DWV pipe. This allows for removal of the fan should it require replacement.

2.4 Ventilation Pipe

Air flow through the system is essential to the operation of the unit and care must be taken to ensure that the vent line is installed correctly. The Ventilation system is used to help the composting process and to prevent odours from escaping into the toilet room

Due to the variety of possible configurations, the vent kit supplied with your CM2 only includes the essential components. Additional DWV pipe and fittings may be required for a complete installation.

The ventilation must be installed in accordance with AS 3500 Clause 6.7.4 where the pipe termination must be as follows;

- 150mm above point of roof penetration.
- 600mm above any building opening that is within a horizontal distance of 3 meters.
- 600mm above any eave that is within 600mm from the vent.

The ventilation piping must be installed with a minimum grade of 1.25% sloping away from the pedestal and should be as short as possible.

CM2 ventilation pipe break-out view Figure 3 next page...

2.0 INSTALLATION

Figure 3: Ventilation pipe components break-out view

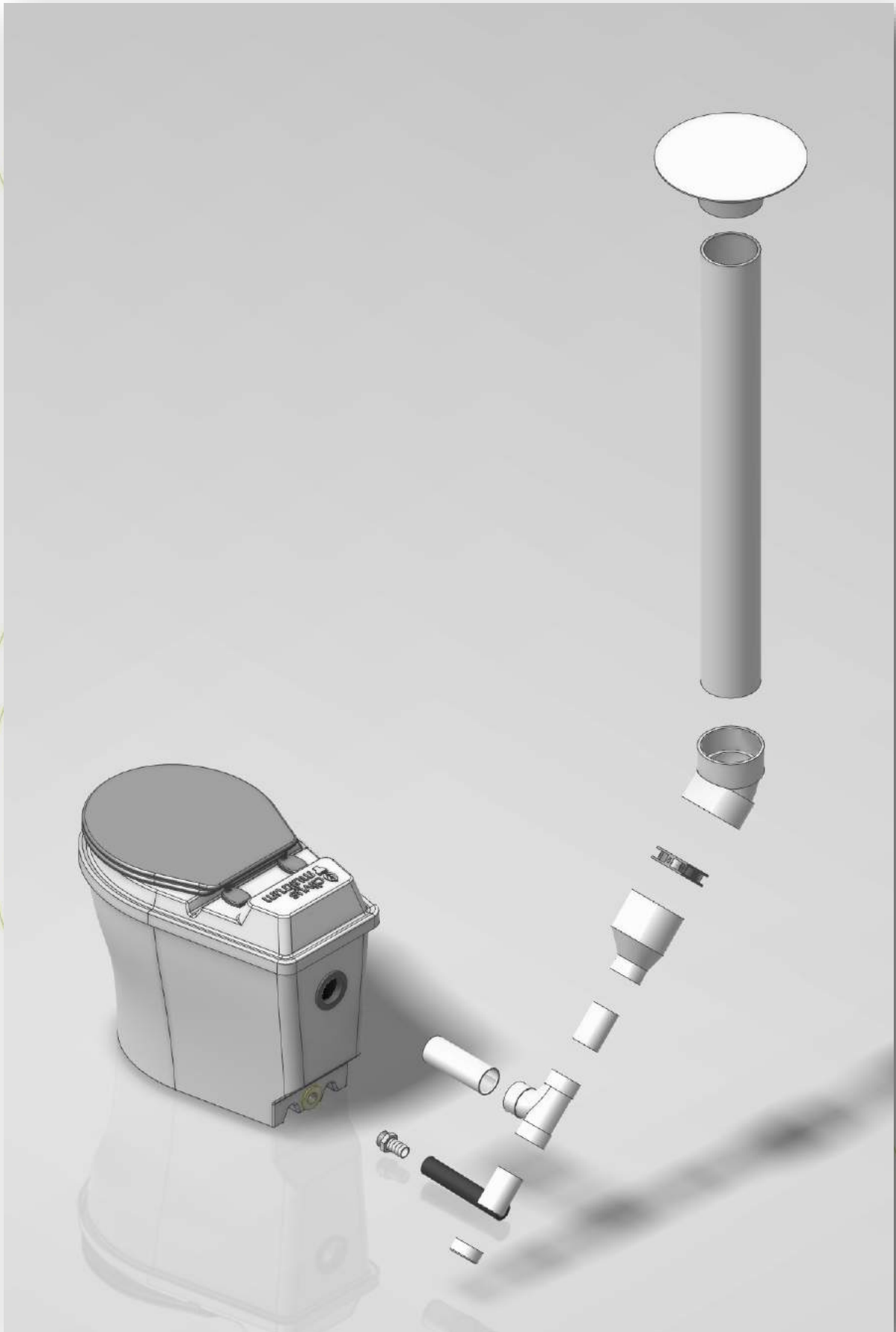

2.0 INSTALLATION

2.5 Ventilation Fan

A 12V DC fan comes pre-assembled in the reducer. It is strongly recommended that the fan be operational 24 hours a day and hence must be connected to a suitable power source.

A 12V DC transformer is supplied with your system which can plug directly into a 240V power point (GPO). The transformer needs to be located under cover.

The power leads from the 12V transformer must be connected to the fan in the reducer. Due to the low voltage it is not necessary for an electrician to make this connection.

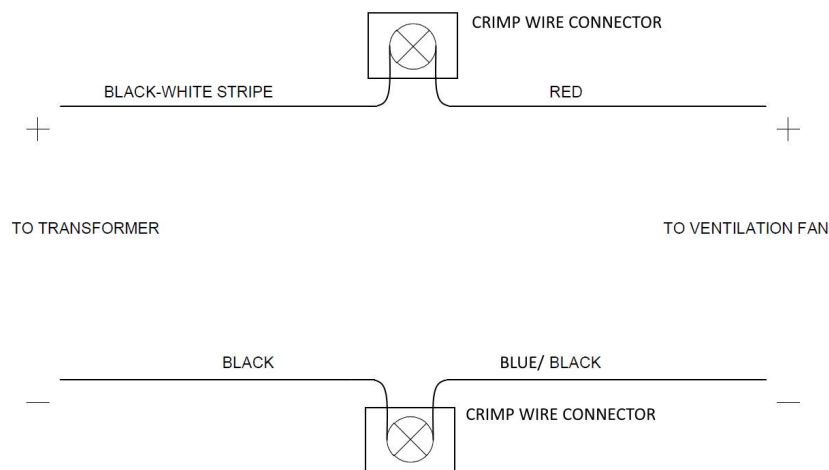

Figure 4: Ventilation Fan Wiring Connection Diagram

If no 240v power socket is available, the fan can be connected to alternative power sources such as a solar power system. Solar kits are available from Clivus Multrum. The fans are rated for voltages between 8 and 15 V DC.

2.6 Passive Ventilation Option

A passive vent system is where no electric fan is used and air flow is induced by the use of a turbo vent and the vent “chimney effect”.

A passive vent system can be installed however a continuous odour free system cannot be guaranteed. This option is only used where the location is remote and no power source is available.

If installing passive vent system the following is recommended:

- Remove the electric fan to ensure unrestricted air flow.
- Increase the vent diameter to 4” DWV PVC as soon as possible after the exit from the pedestal.
- If possible locate the vent on the Northern side of the building in direct sunlight and paint the vent black.
- Install a 100mm turbo vent on top of the vent stack to draw air when there is wind blowing outside. The turbo vent and associated fittings can be purchased from Clivus Multrum.

2.7 Signage

Your CM2 comes with an embossed logo and model number on the top of the unit. The serial number can be located on the back of the unit. Further details such as Clivus Multrum contact details, design capacity, operating condition, electrical requirement and basic notice and instructions are located in the front page of this manual.

2.0 INSTALLATION

2.8 Excess Liquid Drain Installation

The drainage system to be chosen depends entirely on the soil condition, ground water level, and local regulation. Two drainage options for CM2 are recommended as below:

2.8.1 Option I—Absorption Trench

This is the normal method for disposal of excess liquid, but refer to council for permit for any specific requirements. These instructions apply to installation of the drain kit items available from Clivus Multrum.

1. Dig a trench in a position located in front of the liquid end product drain.
2. The trench is to be located in soil of good permeability and in a position where ground water will not flood the unit.
3. If there is some doubt as to the permeability of soil, extra trenching length may be required especially if a hand basin or other fittings will also drain to the same trench.
4. The liquid leaving the compost unit when in use is not expected to exceed 1 litre per day per resident.
5. In some locations it may be desirable or necessary to connect the excess liquid drain to a grey water system or an alternative disposal method complying with AS/NZS 1547:2012.

Trench dimensions and construction are to be in accordance with AS/NZS 1547:2012, as shown in Figure 5.

Figure 5: Durable self supporting arch trench

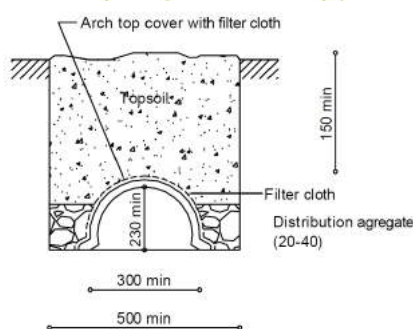

Dimensions in mm.

It is important to ensure that the trench is level along its length. Ensure the liquid drain pipe slopes away from the toilet. Trench should be protected from surface water and flooding, and vehicle traffic.

2.8.2 Option II—25 Litre Translucent Container

This option is for installation with high ground water level, poor permeability or rocks.

Figure 6: Translucent Container 25 Litre Capacity

Excess liquid can be drained into the container. When filled, remove and dilute 1 to 4 with water and use as fertiliser.

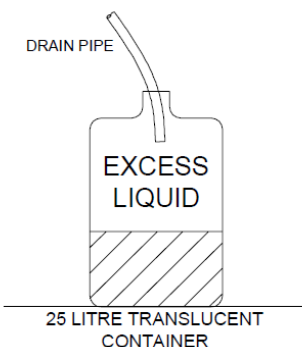

3.0 USING THE CM2

3.1 Initial Setup

1. Once the pedestal has been installed, place one compost chamber inside the pedestal.
2. Remove the chamber lid and put back the pedestal lid. Do not misplace the chamber lid and make sure it is kept somewhere safe.
3. Connect the power outlet for the ventilation fan to power socket.
4. Add 5 litres of Wood Shavings into the composting chamber.
5. CM2 is ready to be used!

4.0 MAINTENANCE

4.1 General Care

The CM2 should be examined regularly to ensure correct operation. The key areas to be checked are listed below:

- Check ventilation fan is running.
- Check there is no access liquid in the compost chamber and pedestal. Refer to Section 7.0 for troubleshooting.

4.2 Removing The Chamber

The active compost chamber should be replaced with an empty one when it is approximately 75% full or when the pile is approximately 200 mm from top of the toilet seat.

1. Remove the pedestal lid and place the chamber lid on.
2. Swing the handle upright and lift the chamber out from the pedestal. When lifting the chamber, please be aware that there may be liquid dripping off from the chamber floor holes.
3. Place the chamber outside for secondary composting. The chamber should be placed in a warm sunny position preferably in warm area such as directly under the sunlight and where direct access is restricted.
4. Put the empty second chamber in the pedestal. Remove the chamber lid and keep it in a safe place.
5. Add Wood Shavings.
6. Put back the pedestal lid.
7. CM2 is ready to be used again.

4.3 When Do I Empty The Secondary Chamber?

As a general rule, you should leave the material in the compost chamber as long as possible. The CM2 has been designed for 2 people full time where the average monthly temperature is greater than 18° C in any given month. Under these conditions the full chamber should only require a maximum of 60 days before it is ready for emptying.

Compost temperature is a significant factor in the time required for composting process. The higher the temperature within the optimum range, the faster the compost process. As a reference, 50 days is required to reach 50% decomposition with a compost temperature ranging between 22-24°C.

Continue next page...

4.0 MAINTENANCE

When ready for disposal the composted end product should not contain recognizable faecal material and there should be no offensive odours immediately after removing the chamber lid.

If there is more than 2 people using the toilet or you are in a colder area then additional compost chambers may be required. Additional compost chambers can be purchased from Clivus Multrum.

4.4 How Do I Dispose The Composted End Product?

Clivus Multrum recommends wearing protective clothing whenever handling waste products. Recommended protective clothing includes gloves, appropriate footwear, a face mask and ideally eye protection.

You should dispose of the composted waste in accordance with any and all local authority regulations. All composted product should be handled and treated with caution as there is a risk of exposure to pathogens particularly if the product is not properly composted.

For an on-site burial of composted end product, it should be undertaken in a location where direct access by human and animals are restricted. It should be buried with a minimum cover of 100mm in soil that is not intended to be used for the cultivation of root vegetables or near a water catchment area.

4.5 Adding Bulking Material

It is important to place bulking material into your toilet, we suggest 1 cup per day directly into the compost chamber. This amount is based on two people using the system full time.

In time of heavy use, or if the liquid is not draining well through the compost, or if compost appears too dry, we suggest you mix the additional Wood Shavings through the compost pile.

By mixing the solid waste, paper and bulking material, the compost will be kept porous and moist, the supply of oxygen will increase, which substantially speeds up the transformation of waste materials into humus.

Bulking material: Untreated wood shavings or other carbon rich material. (Sawdust is not recommended)

4.6 Insects

If insects have entered into your compost, you should sprinkle an insect control powder or any other long lasting pyrethrum based product over the compost chamber.

4.7 Cleaning

Use mild detergents on your CM2. Never use scouring powder or other strong detergents that could scratch the surface, or kill off your good bacteria. We recommend green friendly or septic safe products.

4.8 Warning

Never put cigarettes or other burning material, tampons or sanitary napkins into your toilet!

5.0 HOW COMPOSTING WORKS

5.1 General

Composting involves the biological decomposition of organic matter using natural occurring organisms such as bacteria, fungi and other small organisms into compost which is a humus-like product.

The composting process can be aerobic or anaerobic however aerobic decomposition is desirable because it is efficient and does not produce unpleasant odours. Composting in a Clivus is effectively aerobic however there may be anaerobic decomposition within small pockets within the compost pile.

The composting process involves four main components: microbes (including bacteria, fungi and protozoa), organic matter, water and oxygen.

The carbon compounds present in the organic materials are used by the microorganisms as an energy source and transformed into carbon dioxide using the oxygen present. As the carbon dioxide and water vapor is released into the environment the pile becomes smaller.

Nitrogen is also a crucial element in the composting process which is required by the microbes for cell growth. For optimal decomposition the ratio of carbon to Nitrogen should be around 30:1. Urine and human feces are relatively high in Nitrogen and therefore additional carbon is required for optimal composting.

5.2 Moisture

In optimum conditions, the compost material has consistency of potting mix about 35% to 65% moisture.

When below 35%, there is not sufficient moisture for the microorganisms to function and above 70% saturated conditions begin to develop and oxygen depletion becomes a limiting factor. Under these condition the process becomes anaerobic and the process releases odorous gases such as methane and hydrogen sulphide.

5.3 Temperature

The optimum temperature range for most compost toilets is 18°C to 45°C.

Lower temperatures result in a mouldering process that takes a significantly longer period of time to compost. Additional chambers may be required in this instance.

5.4 Aeration

The aerobic organisms responsible for the composting process require air to survive.

Without air, they will die and be replaced by anaerobic micro organisms that will slow the composting process and generate odour.

For compost toilets to work most effectively, the material being composted should be unsaturated with liquids, and have a loose texture to allow air to circulate freely within the pile.

5.5 Pathogens

Pathogens are eliminated through the long retention times in the compost, the compost temperature and the activity of the micro-organisms.

6.0 WARRANTY

Pedestal:

- 2 years warranty.
- Any damage caused by exceeding the maximum recommended weight listed in specification would void your warranty.

Ventilation Fan

- 12 months limited warranty.
- Powering the fan with unregulated power source exceeding 12V or using power supply not recommended by Clivus Multrum would void your warranty.
- Any faulty fan during the warranty period should be returned to Clivus Multrum before replacement can be provided.

All other components come with standard 12 months warranty.

7.0 TROUBLESHOOTING

A. Why is the compost chamber filling too quickly?

This can be caused by ineffective composting process due to numbers of issue listed below:

Compost pile being too wet—This means liquid is trapped in the compost chamber contributing to quick volume built up. Check if the drainage outlet is being blocked. If drainage outlet is ok, this could be caused by prohibited solids blocking the perforated holes in the floor of the compost chamber.

Insufficient air flow—Without sufficient air flow, the evaporation process will be slowed and odours start to escape into the toilet room. This can be caused by a malfunctioning fan or ventilation system has been blocked. Check if fan is properly connected or replace the fan if broken. Check if the insect netting has been block.

B. Why is the composting process slow to complete?

Composting process is dependent on temperature and humidity. Listed below are factors that could slow down the process:

Compost pile being too wet—The addition of wood shavings is an imperative part of the operation of a composting toilet. Wood shavings will assist with the absorption of liquid in your composting toilet and will aid in improving the carbon/nitrogen ratio (important for composting) and will allow air to flow more freely through the system as it loosens the compost pile.

Continue next page...

7.0 TROUBLESHOOTING

Compost pile surrounding temperature is too low—In cool climates do not insulate the toilet; turn down the fan voltage to lessen cool air being drawn into the system. If odour occurs due to the fan voltage being turned down low simply turn it up slightly to increase airflow.

When taking the compost chamber out for secondary composting, make sure it is located in a warm spot preferably in direct sunlight.

C. **How to deal with insects attracted to compost pile?**

Insect Control—To break the breeding cycle of insects (most commonly, vinegar flies) spray the compost pile with pyrethrum based insect spray for 7 consecutive days. Always place a layer of wood shavings over the top of the pile in the out of service chamber to eliminate the possibility of insects laying eggs.